

August 2022

Framed Openings: A Walk-Through

You have a choice: field vs. factory located framed openings. Which do I need? Does it matter? These could be questions you may ask yourself when specifying wall openings in your building. This article walks through the difference between the two types of openings as well as how framed openings are engineered differently based on the selected type. These questions are important to keep in mind when ordering and erecting your building to ensure you receive what you are expecting.

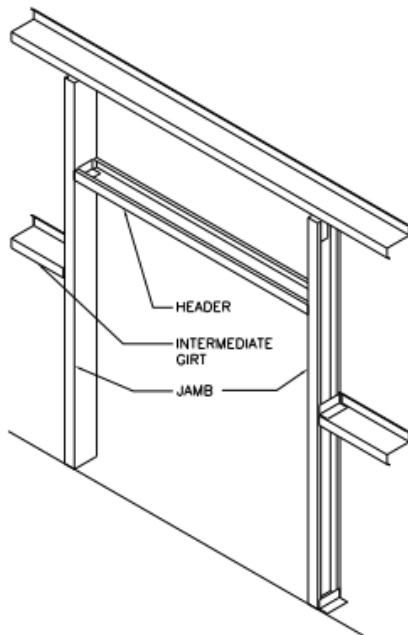

Standard Framed Opening Configuration

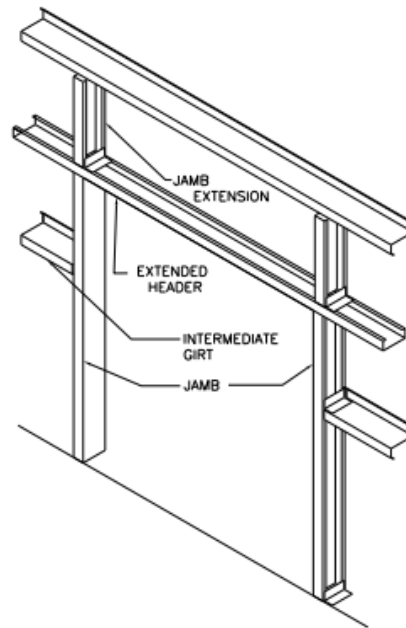

Extended Header Framed Opening Configuration

When deciding what type of framed opening to use, consider the flexibility you'll need in the field during the erection process. Factory located framed openings give the precise location of the opening; a field located framed opening is assumed to be at any given location within the specific bay in which it is located in the order documents. Factory located framed openings typically result in lighter, more cost-effective solutions. Field located framed openings have the advantage of allowing adjustability for their installment during erection, however, they can lead to heavier framing solutions that may increase the price of the metal building. Field cutting, wasting material, and field drilling holes must be considered to match the location where the framed opening is installed. One solution that is helpful with multiple identical field located framed openings is specifying the use of a cold-formed cee channel as the header and sill member. This allows for easy movement of the specific framed openings in the bays that the cees are added. In addition, always be conscious of locating openings too close to columns; this limits the use of flange bracing on rigid frame columns and the depth of portal frame columns. Restrictions on portal column depths and flange bracing always result in less economical framing solutions.

When designing framed openings (field and factory located), engineers design the framed opening materials and surrounding girts to rely on each other in a wind event. Walls are designed as a specific system of members that work together to distribute wind load to a buildings' rigid frames and longitudinal bracing. It is assumed that a field located framed opening will remain in the bay that is specified in the order documents and that all openings are to be installed in the metal building. If framed openings are moved to a different bay than what was specified in the order documents, the structural integrity of the surrounding girts could be compromised. It is always necessary to contact your project coordinator if you plan to move field located framed openings into a different bay so that CBC can review any impacts to the metal building.

To conclude, the advantages of using factory located framed openings often result in lighter framing, and in turn a more cost-effective solution. Field located framed openings typically include heavier framing and field work which could increase the price of your building, but also offer flexibility in the field during erection. If you are looking for more economical framing methods, being more specific with framed opening locations will prove to be a helpful tool.