

December 2022

Choosing Between a Pinned or Fixed Base Column

Using fixed versus pinned base columns could have an impact on the overall cost of a project. Do you put more money into the steel structure to support the loads and deflections? Or, do you put more money into the foundations to resist additional reactions?

The difference between these column base connections can be illustrated with a flagpole. A flagpole is a fixed base member that carries its own weight, as well as any wind that blows on it. If the pole was a pinned base it would want to fall over like there was a hinge at the bottom.

A pinned base column is the most common base found in metal buildings. This connection is pinned because it has enough strength to apply horizontal and vertical loads to the foundations, but enough flexibility to not apply direct moment. When deflection requirements are more stringent than that standard $H/60$, pinned base frames may require material to be added to columns and/or rafters, in some situations in excess of that required for strength. This type of base connection requires fewer and typically smaller anchor rods when compared to a fixed base connection.

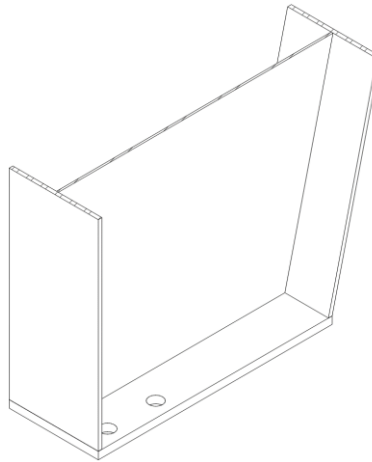

Figure 1 - Typical Pin Base Column

A fixed base column is more of a special situation base connection in metal buildings. This base has a lot of strength and stiffness causing it to apply horizontal, vertical, and moment loads to the foundations. The additional stiffness at the base and columns means less stiffness is required from the rest of the frame members and connections. It is common for columns using fixed base connections to be straight and deeper than its pinned base counterpart. The foundations may need to be larger than the pinned base due to this moment. The installation of fixed base columns may be more difficult due to more anchor rods being required and the additional materials on the baseplates. There are a few options for this condition depending on the size of the building and the loading.

Common scenarios where a fixed base column may be used or provide an economical solution for the Metal Building include: Stepped Crane Columns, High-Deflection Requirement buildings, Tall buildings (approx. 60ft or greater), T-Frames (common for lumber storage, parking lot solar structures, etc.), Wide Clear-Span structures, etc. Coordination with the Design Professional Responsible for the foundation and our NBG estimating or design teams, can aid in helping determine if fixed based columns are right for a project.

Deflection Example:

Framing Type: Rigid Modular Single-Slope (2 @ 50'-0")
 Building Width: 100'-0"
 Building Low Eave Height: 40'-0"
 Slope: 0.5:12
 10-year wind Sidesway Required = H/360

	<u>Pinned Base</u>		<u>Fixed Base</u>
	Typ. MB Dsn	H/360	
Frame weight:	6,969 lbs	12,929 lbs	7,784 lbs
Frame Sidesway:	H/68	H/364	H/397

Note: These results cannot be applied to projects of similar size. Location will determine the economics of your building.

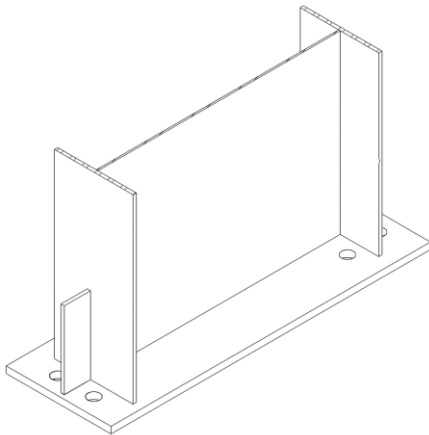

Figure 2 - Lightly Loaded Fixed Base

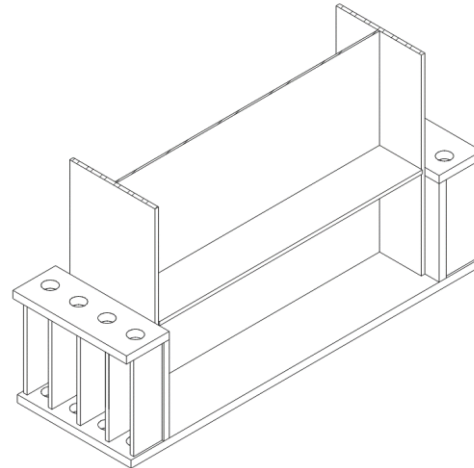

Figure 3 - Heavily Loaded Fixed Base